

Document Name	Document Version Number	Review Date
Backflow Prevention Policy	1.0.1	June 2025
Date Adopted	Minute Number	Status
19 July 2023	6469	Revised

## 1. Background

Backflow is the undesirable reverse flow of water from a potentially polluted or contaminated source to Council's potable water supply system. Backflow into the reticulation network presents a public health risk to drinking water supplies. Backflow is typically caused by cross-connections or a failure of backflow prevention devices. Backflow may allow the ingress of pathogens, chemical contaminants or detritus into the reticulation network, and increases the health risks for all customers.

The management of backflow prevention requires both the identification of risk associated with a customer's premises as well as monitoring of backflow prevention devices.

## 2. Policy Objectives

The objectives of this policy are to:

- Ensure the integrity of the potable water distribution system by minimising the risk of backflow from customers' properties.
- Specify when testable backflow prevention devices are required to be installed at properties, i.e. for medium and high hazard ratings.
- Provide information to members of the public, plumbers and other stakeholders about Council's requirements and role on backflow prevention.
- Ensure that non-complying properties are brought into line with the requirements of this procedure, Plumbing Code of Australia and the Australian Standard AS 3500 Part 1.
- Maintain backflow records/register.
- Ensure backflow prevention containment devices are fit for purpose.
- Ensure annual testing is carried out by an **Authorised Person**, where required, and information is added to the Council backflow register.
- Investigate non-compliance and ensure enforcement of this policy/procedure.

### 2.1 Purpose

This policy deals with the prevention of backflow of water from customers' properties back into Greater Hume Council's potable water distribution system. This policy is not intended to provide guidance regarding the prevention of hazardous backflow within a customer's service.

### 2.2 Scope

This policy includes the prevention of backflow of water into Council's potable water distribution system, including responsibilities of Council and the customer. Council operates two drinking water supply systems:

- Culcairn supply
- Villages supply (Jindera, Burrumbuttock, Brocklesby, Gerogery, Gerogery West)

Other townships within the Council area are supplied drinking water by Riverina Water. Customers serviced by Riverina Water should consult the Riverina Water Backflow Prevention Policy on their website for guidance.

## 2.3 Principles of Backflow Prevention

The drinking water distribution system operated by Council relies on appropriate backflow prevention as one of the important measures to maintain the safety of the water supply to all consumers.

Backflow prevention may be provided by a number of layers, depending on the hazard:

- *Individual Protection*: Used to protect a water service from a specific hazard from a fixture, appliance or other device
- *Zone Protection*: Used to protect the water supply within a residential or commercial service from backflow from one or more hazards within the facility
- *Containment Protection*: Used to protect Council's drinking water system from backflow hazards from connected services.

In addition to containment protection to protect Council's water distribution system, backflow prevention using zone protection or individual protection should be applied within customer boundaries as required based on the level of risk to maintain the safety of the service (refer Figure 1).

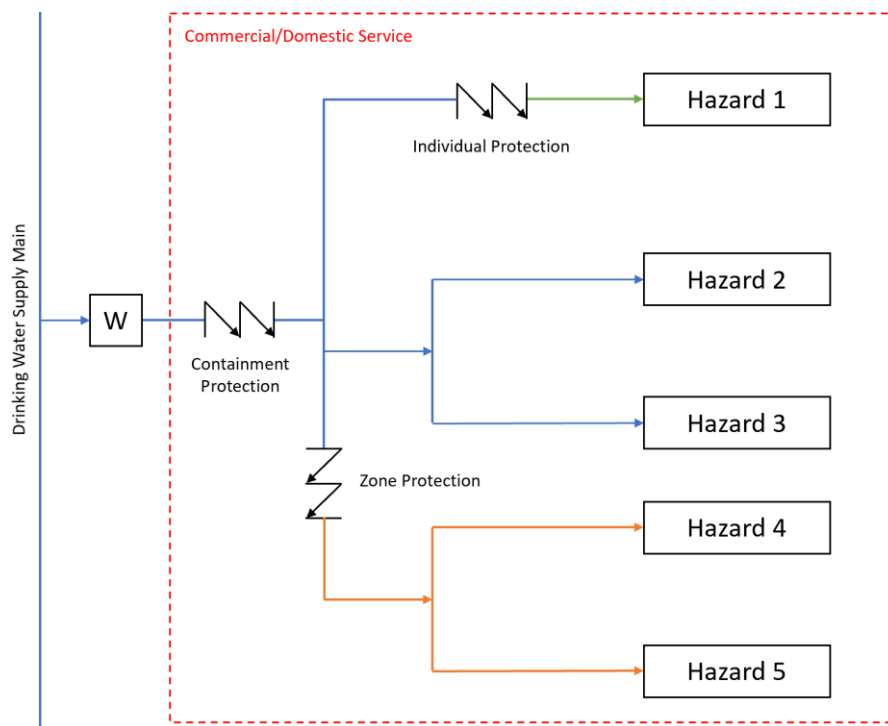

**Figure 1 Layers of Backflow Prevention**

To determine the required backflow prevention within a service, customers should:

- Identify hazards that may affect water safety within their service network, property and adjacent properties
- Assess the level of risk associated with each hazard
- Select and locate backflow prevention devices to isolate hazards both within their service and to isolate all hazards from Council's supply system.

It is important to protect Council's water distribution system against all hazards. Individual or zonal protection should be used in combination with containment protection for all customer connections.

This policy relates specifically to the protection of Council's water distribution system against backflow from customer connections (containment protection). For further information on protection services against backflow within a customer premise, refer to *AS3500.1 Plumbing and Drainage – Water Services* and the *National Construction Code Part 3 – Plumbing Code of Australia*.

## 2.4 Levels of Hazard

Cross-connections are rated using three degrees of hazard:

- **High:** Any condition, device or practice which has the potential to contaminate Council's water distribution system and cause death.
- **Medium:** Any condition, device or practice which has the potential to contaminate Council's water distribution system and cause illness.
- **Low:** Any condition, device or practice which would be a nuisance but does not endanger public health.

Hazards to a water service generally consists of conditions, devices or practices conducted at a customers' premises, however a hazard assessment should consider premises in close proximity to any outlets, taps or other means of ingress from spraying hazards such as irrigation systems.

A list of common types of premises and typical cross-connection hazard is provided in Appendix A. Council should be contacted where customers, building consultants or licensed plumbers are uncertain of the hazard rating of a property. A site assessment may be required to allow the property hazard rating to be correctly determined.

## 2.5 Types of Backflow Prevention Devices

A number of different types of BFPDs are available, with different devices providing different types of protection, redundancy and testability. Common BFPDs are listed in Table 1.

**Table 1 Types of Backflow Prevention Device.**

Device	Hazard Suitability	Testable?	Backpressure Protection	Back-Siphonage Protection
Registered Break Tank	High/Med/Low	Yes	Yes	Yes
Registered Air Gap	High/Med/Low	Yes	Yes	Yes
Reduced Pressure Zone Device (RPZD)	High/Med/Low	Yes	Yes	Yes
Double Check Valve Assembly with test ports (DCV)	Med/Low	Yes	Yes	Yes
Pressure Type Vacuum Breaker with test ports (PVB)	Med/Low	Yes	No	Yes
Dual Check Valve Assembly without test ports	Low	No	Yes	Yes
Air Gap	Low	No	No	Yes
Break Tank	Low	No	No	Yes
Vacuum Breaker without test ports	Low	No	No	Yes
Single Check Valve with test ports (SCVT)	Low (Fire Services Only)	Yes	Yes	Yes
Single Check Valve without test ports	Not a backflow prevention device	No	No	No

## 2.6 Selecting the Correct Device

A number of backflow prevention devices exists. Backflow prevention devices can be classified into:

- Registered testable devices
- Non-testable devices.

Non-testable devices should only be used for low cross-connection hazards. All medium and high cross-connection hazards should be contained with registered testable devices.

Backflow prevention devices should be selected as appropriate to the hazard, considering whether protection against backpressure is required or whether only back-siphonage is required. Table 1 provides a reference of common BFPDs, suitability for protection against hazards as well as back-pressure/back-siphonage.

A list of typical hazard ratings and backflow prevention devices is provided in Appendix A. Council should be contacted where customers, building consultants or licensed plumbers are uncertain of the hazard rating of a property. A site assessment may be required to allow the property hazard rating to be correctly determined.

## 2.7 Installation Requirements

Backflow prevention devices should be installed as per *AS3500.1 Plumbing and Drainage – Water Services* and the *National Construction Code Part 3 – Plumbing Code of Australia*.

Installation of BFPDs is considered ‘plumbing and drainage work’ under *Plumbing and Drainage Act 2011* in all circumstances, including work conducted by an owner/occupier. Backflow prevention devices must only be installed by an **Authorised Person**.

Prior to installing the BFPD, Council may require a plumbing application to be submitted prior to the commencement of works. Any application should be made using an *Application for Development/Construction Form* available from Council’s website.

A number of specific requirements relating to the installation of BFPDs should be noted:

- BFPDs should be located to allow regular inspection and maintenance
- BFPDs must always be located above ground level and protected against vandalism, weather and other damage
- BFPDs must be installed as close as practical and downstream of the water meter for the site
- The BFPD must not be bypassed, and no connections are permitted between the water meter and the BFPD
- Line strainers must be installed prior to the following devices:
  - pressure type vacuum breakers
  - double check valves
  - reduced pressure zone devices
- Isolation valves should be provided before and after all testable BFPDs
- Where a strainer is fitted to a BFPD, the inlet isolation valve should be located before the strainer.

After installation is completed, customers must ensure that all testable BFPDs are commissioned by an Authorised Person, and a certificate of test is submitted to Council. Council may require that the works are inspected, and a 48-hour notice period should be considered where an inspection is required.

## 2.8 Authorised Persons

Backflow prevention devices must only be installed, commissioned and tested by an Authorised Person. Under the *Plumbing and Drainage Act 2011*, an Authorised Person is someone who:

- Holds a contractor licence or supervisor certificate endorsed for *Plumbing* or *Water Plumbing*.
- Works under the immediate supervision of the holder of the contractor licence or supervisor certificate.

## 3 Responsibilities

Council will operate a system of compliance to ensure that customers comply with this policy. In the absence of any site-specific information, Council will assign a hazard rating to a property based on Council's assessment of the primary activities being undertaken on site.

Council may update the rating from time to time, as required. A customer can request for a review of the hazard rating by providing more site-specific information.

Council will keep records of the backflow hazard rating of all properties. Council may ask customers to test and/or certify their backflow prevention devices periodically. Council requires that the commissioning, testing and certification is carried out by Authorised Personnel.

Council will keep records and ensure that minimum requirements for Testable Devices are carried out. These are:

- All testable backflow devices must be registered with Council and tested on installation.
- All testable devices with medium or high hazard rating must be tested at intervals no greater than 12 months and testing is to be carried out by an Authorised Person.
- Council will advise customers of the date when the device must be tested by, and the test results should be forwarded to Council within 20 working days of testing.

Council will apply this policy to BFPD requirements (installation and annual testing) to the services it maintains (e.g. sewerage treatment plants).

### 3.1 Customer Responsibilities

The customer is responsible for installation of the appropriate backflow prevention devices including containment protection, on their property that has a high or medium hazard rating.

The customer must engage an Authorised Person to install the backflow device. In the case of existing water services, the customer must assess the hazard rating (advice from Council can be sought) and, where required, provide certification of the backflow device by an Authorised Person to Council in a timeframe agreed by Council.

In the case of a new water service, the customer must provide certification of the backflow device by an Authorised Person prior to Council making water services available.

The customer is responsible for the ongoing maintenance and certification of the backflow device. Upon advice from Council on the need to do so, the customer must submit certification of the satisfactory operation of the backflow device to Council within 20 days of the issue of the advice.

Where the customer fails to provide the certification by the due date, Council may do one or more of the following:

- Test and certify the device and charge a fee to the customer
- Issue reminder notice(s) to the customer and charge an administrative fee to the customer.
- Disconnect the water service if Council believes that the hazard presented by the activities on the property presents an unacceptable risk to the water supply and charge a fee for the disconnection/reconnection.

Except with the written approval of Council, the property owner/occupier shall not alter in any form the installation or operation of the device referred to in the original approval, including replacement or removal of the backflow devices.

Where the hazard rating for new commercial and industrial developments is unknown, a testable BFPD must be installed.

## 3.2 Flow Chart for Installation of a New BFPD

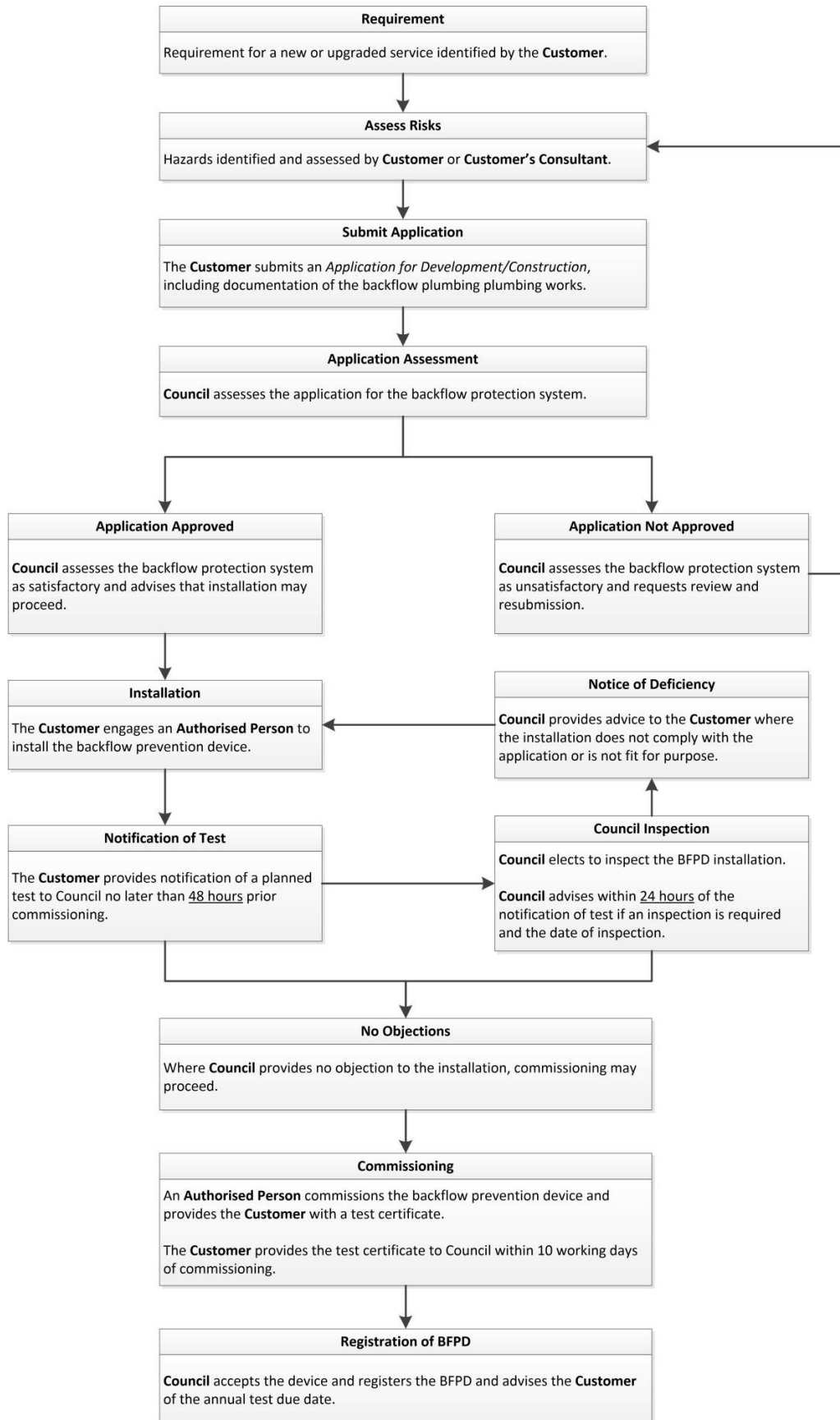



## 3.3 Annual Flow Testing Chart

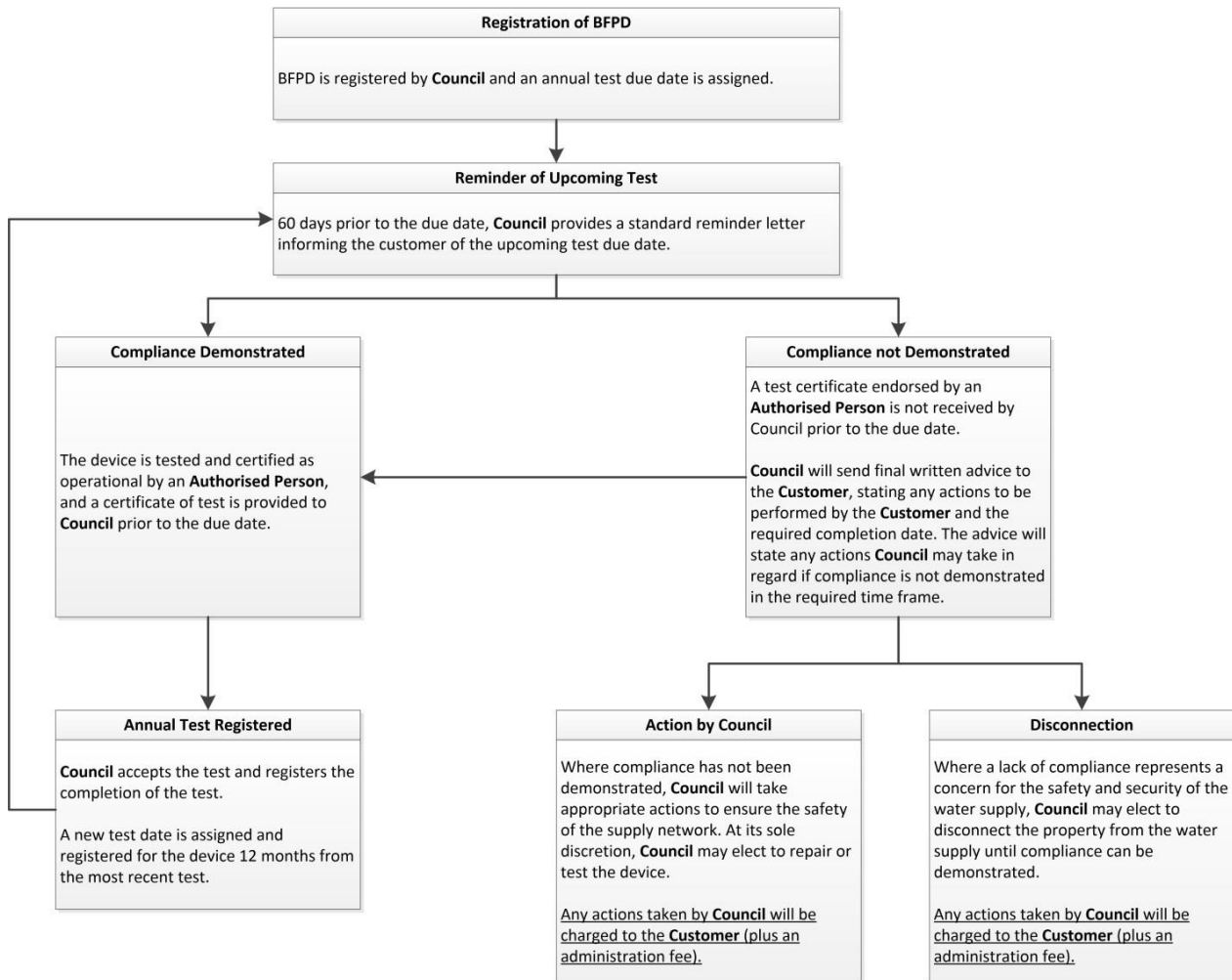

## 4 Glossary

**Authorised Person:** A person authorised under the *Plumbing and Drainage Act 2011* to perform plumbing works on water systems.

**Backflow:** Backflow is the unintended reversal of flow in a water pipeline whereby water from the customer's pipeline system returns to the Council's water supply.

**BFPD:** Backflow prevention device.

**Testable BFPD:** A backflow prevention device with appropriate testing ports as defined by *AS3500.1* and registered with Council.

**Un-Testable BFPD:** Any backflow prevention device that is not a testable BFPD.

**Water Distribution System:** Network of pipes leading from a water treatment plant to customers' plumbing systems.

## 5 Records

- Record all medium and high-risk customers on the *Annual Backflow Testing Register*, including risk rating and testing due date.
- When a customer advises that backflow testing is complete, file the certificate of test on the Council drive and record the certification on the *Annual Backflow Testing Register*.

## 6 Related Documents

Document Number	Description
AS3500.1	Plumbing and Drainage – Water Services
POL-2.1	Riverina Water Backflow Prevention Policy
REC-18-258	Annual Backflow Testing Register
N/A	Application for Development/Construction Form
N/A	Fact Sheet – Plumbing Applications and Permits
N/A	National Construction Code Part 3 – Plumbing Code of Australia

## Appendix A

### Hazard Ratings and Backflow Prevention Devices for Common Premise Types

#### Legend:

- RBT:** Registered break tank  
**RPZD:** Reduced pressure zone device  
**RPDA:** Reduce pressure detector assembly  
**DCV:** Double check valve  
**DCDA:** Double check detector assembly

Type of Premises	Typical Hazard Rating	Backflow Prevention Device
Premises with an alternative water supply (excluding rainwater tanks)	High	RBT or RPZD
Premises where inspection is restricted	High	RBT or RPZD
Hospitals, mortuaries, clinics	High	RBT or RPZD
Piers, docks and other waterfront facilities	High	RBT or RPZD
Sewage treatment plants and pump stations	High	RBT or RPZD
Factories using, processing or manufacturing toxic chemicals	High	RBT or RPZD
Petroleum processes or storage plants	High	RBT or RPZD
Car and plant washing facilities	High	RBT or RPZD
Abattoirs	High	RBT or RPZD
Chemical laboratories	High	RBT or RPZD
Pathology laboratories	High	RBT or RPZD



Type of Premises	Typical Hazard Rating	Backflow Prevention Device
Sanitary depots	High	RBT or RPZD
Universities	High	RBT or RPZD
Food and beverage processing plants	Medium	Testable device
Caravan parks	Medium	Testable device
Marinas	Medium	Testable device
Premises with greywater re-use systems	Medium	Testable device
Public swimming pools	Medium	Testable device
Premises with reticulated and disinfected reclaimed water systems	Medium	Testable device
Premises with rainwater tanks	Low	Non-testable device
Premises with reticulated recycled water systems	Low	Non-testable device
All premises – fire services	Low	SCVT or SCDAT
All premises – fire services	Medium	DCV or DCDA
All premises – fire services	High	RBT, RPZD or RPDA

**Document Author**  
Viridis Consultants